

TEMPO 190

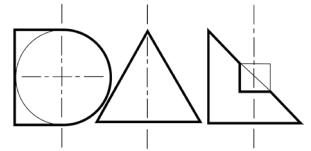

TEMPO 190 Round recessed downlighter with standard white ceiling trim and a choice of deep cone reflector finish and wide beam distribution. The high-quality precision light controller with deep cone aluminium reflector gives visual comfort. The TEMPO 190 is easy to install and incorporates the latest, high efficiency LED technology. Colour consistency through life is ensured by state-of-the-art components and passive cooling aluminium heat sinks.

Standard colour temperatures: 2700K, 3000K, 3500K, 4000K, colour rendering Ra >80/Ra>90 2/3 step Macadam are all available. Life 50000 hours. A choice of drivers provide fixed supply or dimming to project requirements. IP20 or IP44 durable, high specification diecast construction, colour powder coat finish provides longevity.

Built to conform to the requirements of BS EN 60598-1 and IEC 598.

Photometrically tested to LM-79-08 confirms TEMPO X190 high performance.

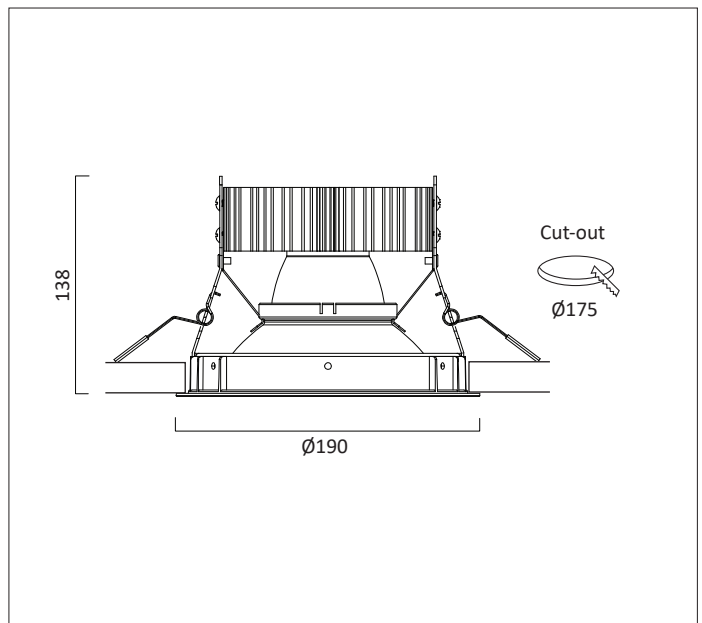

LED	IP Rating	Beam	Specular Silver	Satin Silver	White
XICATO	IP20	80°	G5181	G5182	G5184
XICATO	IP44	80°	G5281	G5282	G5284
CREE	IP20	80°	G5381	G5382	G5384
CREE	IP44	80°	G5481	G5482	G5484
BRIDGELUX (Tunable)	IP20	73°	G5581	G5582	G5584

XICATO

LIGHT ENGINE - Ra >80 2 step Macadam - 19mm LIGHT ENGINE - XTM

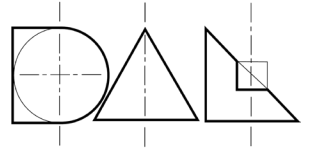

Engine Order Code	Initial Output Lumens	Delivered Lumens	CCT	CRI	Pd (W)	Vf forward typical	Current
20A2	2000	1530	2700K	80+	15.2	21.7	700mA
30A2	3000	2295	2700K	80+	25.7	24.4	1050mA
38A2	3850	2946	2700K	80+	30.5	29.0	1050mA
20A3	2000	1530	3000K	80+	15.2	21.7	700mA
30A3	3000	2295	3000K	80+	25.7	24.4	1050mA
38A3	3850	2946	3000K	80+	30.5	29.0	1050mA
20A3	2000	1530	3500K	80+	15.2	21.7	700mA
30A3	3000	2295	3500K	80+	25.7	24.4	1050mA
38A3	3850	2946	3500K	80+	30.5	29.0	1050mA
20A5	2000	1530	4000K	80+	15.2	21.7	700mA
30A5	3000	2295	4000K	80+	25.7	24.4	1050mA
38A5	3850	2946	4000K	80+	30.5	29.0	1050mA

CREE

LIGHT ENGINE Ra >90 3 step Macadam - 19mm LIGHT ENGINE - CXB2540

Engine Order Code	Initial Output Lumens	Delivered Lumens	CCT	CRI	Pd (W)	Vf forward typical	Current
20J2	2000	1530	2700K	90	13.1	32.7	400mA
25J2	2500	1912	2700K	90	16.5	33.0	500mA
34J2	3400	2601	2700K	90	23.5	33.6	700mA
22J3	2200	1683	3000K	90	13.1	32.7	400mA
27J3	2700	2065	3000K	90	16.5	33.0	500mA
36J3	3600	2754	3000K	90	23.5	33.6	700mA
23J3	2300	1760	3500K	90	13.1	32.7	400mA
28J3	2800	2142	3500K	90	16.5	33.0	500mA
38J3	3800	2907	3500K	90	23.5	33.6	700mA
24J3	2400	1836	4000K	90	13.1	32.7	400mA
30J3	3000	2295	4000K	90	20.0	33.3	500mA
40J3	4000	3060	4000K	90	23.5	33.6	700mA

Tolerance range for optical and electrical data: $\pm 10\%$.

Other Output, CCT and CRI are available on request.

BRIDGELUX - TUNABLE

LIGHT ENGINE 2700-6500K- BXRV-TR-2765G-40A0-A-2x

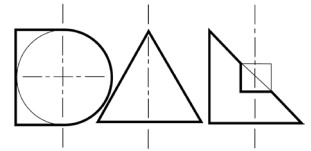

Engine Order Code	Initial Output Lumens	Delivered Lumens	CCT	CRI	Pd (W)	Vf forward typical	Current per channel
2750G	3548-3741	2838-2992	2700-5000K	92	31.7	34.9-35.3	900mA
2765G	3548-4026	2838-3220	2700-6500K	92	31.7	34.9-35.3	900mA

DRIVERS & EMERGENCY

Driver
Order Code

0	FIXED
1	1-10V
3	DSI
5	DALI
7	LEAD / TRAIL

Emergency
Order Code

0	No emergency
E	3 hour maintained emergency pack
9E	with DALI Addressable with full error feed back

PHOTOMETRIC DATA

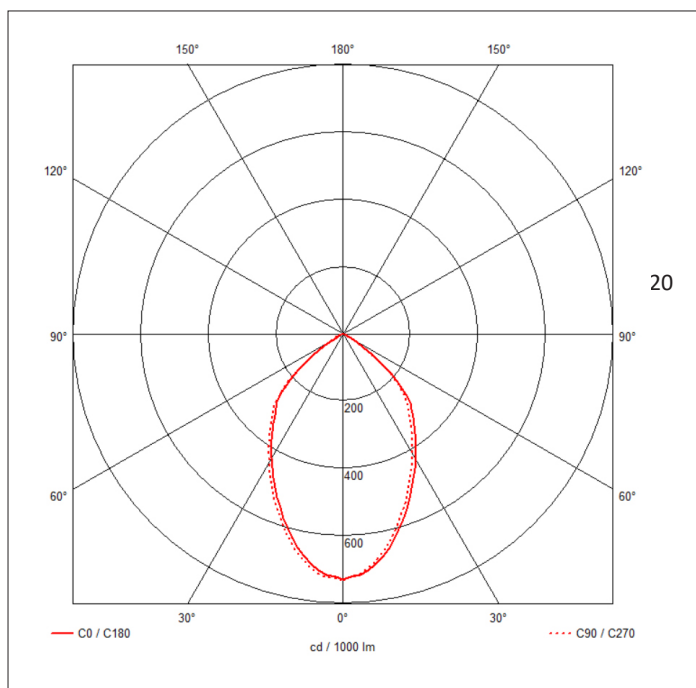

Full Product Number Example

G5382-40J3550

G53 CREE LED- IP20

8 80°

2 Satin Silver

40 4000 lumens (Initial)

J CRI >90 - 3 Step MacAdam

5 4000K

5 DALI Driver

0 No Emergency